

BILL OF MATERIAL		DESCRIPTION		B.V.I. NO.	
ITEM	QTY.	U/M	DESCRIPTION	B.V.I. NO.	

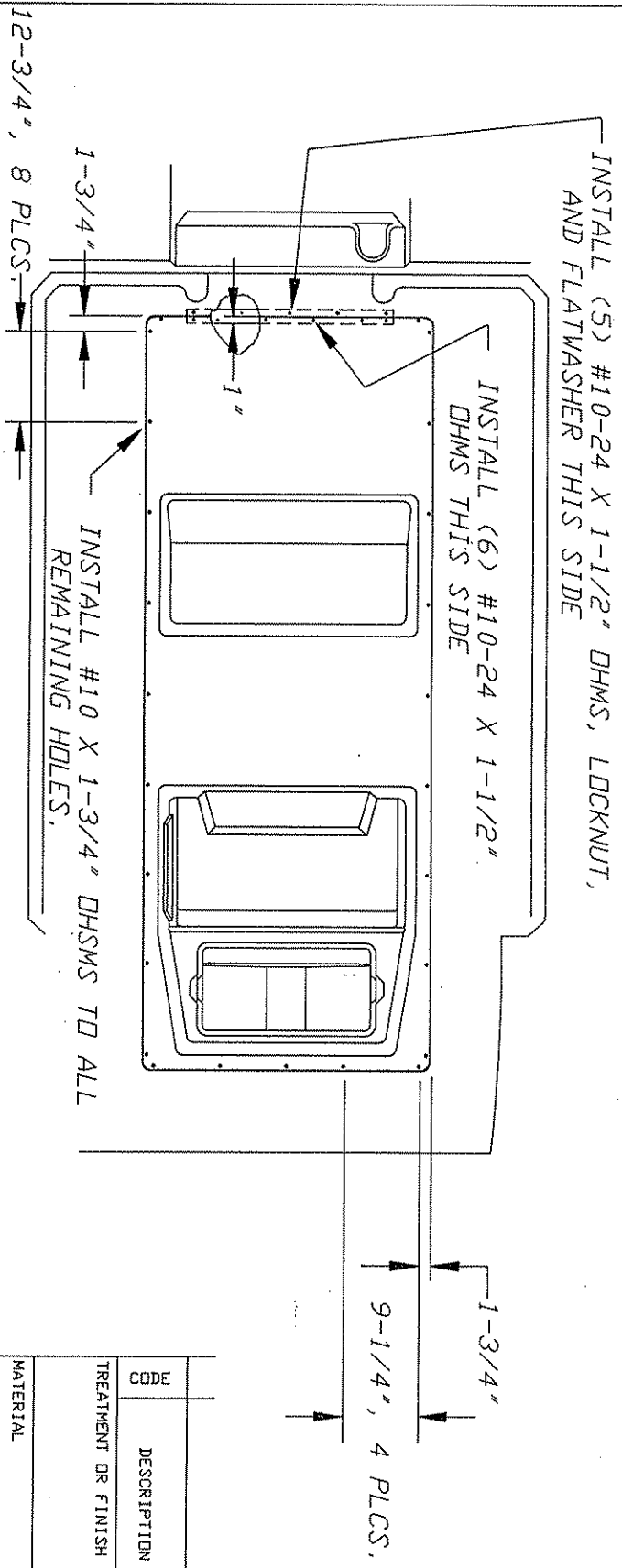

TANK REMOVAL/INSTALLATION INSTRUCTIONS

1. PLACE BACK-UP PLATE ON DECK AS SHOWN ABOVE, CENTERING ON 'CUT LINE' AND CENTERLINE OF BOAT. MARK PREDRILLED HOLES (5) ON DECK FOR LATER INSTALLATION OF PLATE. IF NECESSARY, SLIGHTLY DRILL EACH HOLE SO THAT MARKINGS WILL NOT BE LOST.
2. PRIOR TO CUTTING DECK, DISCONNECT THE FOLLOWING: (RETAIN ALL REMOVED MOUNTING HARDWARE)

CODE	DESCRIPTION	DATE	BY	APPD
TREATMENT OR FINISH				
MATERIAL				
SCALE	DRAWN T. JOHNSON			
DATE	CHKD.			
12/5/91	APPD.			
ENGINEERING DEPARTMENT				
TITLE				
FIELD FIX KIT, 190R II FUEL TANK				

- (a) FUEL FILL HOSE, (1-1/2")
 - (b) FUEL VENT HOSE
 - (c) BONDING WIRE, (FILL TO TANK)
 - (d) FUEL SENDING UNIT WIRING
 - (e) SALTWATER WASH OUTLET/LIVWELL FILL CONNECTIONS
 - (f) LIVWELL DRAIN HOSE
 - (g) STEERING/THRUSTLE CABLES
 - (h) BATTERY CABLES
 - (i) COURTESY LIGHTS AT CONSOLE BASE
 - (j) CONSOLE WIRING, (ALLOWEE SHEET 5)
3. REMOVE THE FOLLOWING, (TO PREVENT DAMAGE):
 - (a) CONSOLE, (REMOVE SCREWS AT HINGE, RETAIN)
 - (b) CONSOLE FRONT SEAT AND BASE
 - (c) SEATS OR LEANING POST
 - (d) CONSOLE LOWER SHELVES, (2)
 4. AFTER ALL DISCONNECTIONS/REMOVALS ARE COMPLETED, PROTECT WIRING AND HOSES THAT ARE INSTALLED IN THE FORWARD SIDE TROUGH(S) BY PLACING A BLOCK OF WOOD, (OR ANY SUITABLE MATERIAL), OVER THEM PRIOR TO ANY CUTTING.
 5. BEGIN CUTTING DECK LINE, TAKING CARE TO STAY CENTERED IN THE CUTTING GROOVE, CUTTING APPROX. 3/4" DEEP, (1" MAX.).
 6. CAREFULLY REMOVE DECK FROM BOAT, MAKING SURE ALL DISCONNECTIONS ARE MADE.
 7. REMOVE BONDING WIRES AND TANK HOLDDOWNS (4), RETAIN HARDWARE FOR REINSTALLATION.
 8. REMOVE WIRING TROUGH, SET OFF TO THE SIDE.
 9. USING A HAND SAW, CUT DOWN BETWEEN FUEL TANK AND FOAM UNTIL 'BOTTOMED-OUT' AGAINST CAVITY, (DO NOT CUT CAVITY), ON P/S SIDES.
 10. ONCE FOAM IS CUT, LIFT AND PULL TANK TO RELEASE IT FROM THE FOAM AT THE AFT END OF THE TANK.
 11. REMOVE TANK BY BRINGING IT UP FORWARD AND UP OUT OF CAVITY. ONCE OUT CAVITY, SCRAPE ANY REMAINING FOAM FROM OFF OF THE TANK.

SCALE	DRAWN T. JOHNSON	
DATE	CHKD.	
12/5/91	APPD.	
ENGINEERING DEPARTMENT		
FILE FIELD FIX KIT, 190R II FUEL TANK		

12. CUT OUT/SCRAPE FOAM FROM INSIDE OF TANK CAVITY, TAKING CARE NOT TO DAMAGE CAVITY.

13. INSTALL NEW TANK INTO CAVITY, POSITION (2) PIECES OF PROVIDED PIPE INSULATION APPROX. 2" APART AT THE AFT END OF THE TANK, (VERTICALLY, FOR WATER DRAINAGE), THEN REINSTALL TANK HOLDDOWNS. MAKE SURE HOLDDOWNS ARE OVER TOP OF TANK BAFFLES.

14. REFOAM TANK, TRIM EXCESS FROM AROUND TOP EDGES.
NOTE: FOAM FOR THE AFT END OF THE TANK MUST BE Poured THROUGH THE ACCESS PLATES LOCATED AT THE FORWARD END OF THE MOTORWELL, TAKING CARE TO PREVENT SPILLAGE ONTO TANK.

15. REINSTALL BONDING WIRES AND WIRING TROUGH USING RETAINED HARDWARE, RECONNECT FUEL SENDER WIRING AND FUEL VENT LINE.

16. RECONNECT FUEL FILL HOSE AND BONDING WIRE TO THE FUEL FILL.

17. PRIOR TO INSTALLING DECK, DRILL AND COUNTERSINK HOLES PREVIOUSLY MARKED ON THE AFT END OF THE COCKPIT FLOOR FOR #10 SCREWS, THRU-BOLT PLATE TO THE FLOOR USING THE HARDWARE PROVIDED, (#10-24 X 1-1/2" OHMS, LOCKNUT, & WASHER), 5 PLCS.

18. REPOSITION DECK ONTO BOAT, DRILL AND COUNTERSINK HOLES FOR #10 OHMS AS SHOWN ON SHEET 1 OF 5. DRILL AND TAP HOLES AT AFT END OF DECK WHERE PREVIOUSLY MARKED #10-24 THROUGH BACK-UP PLATE. AFTER INSTALLING SCREWS PROVIDED, RUN A BEAD OF RTV AROUND ENTIRE CUT LINE FOR WATER SEAL.

19. REINSTALL CONSOLE SHELVES, RE-ROUTE WIRING AND CABLES UP THROUGH CONSOLE BASE, THEN REINSTALL CONSOLE. RECONNECT WIRING AND CABLES INSIDE CONSOLE, THEN ALL PREVIOUSLY REMOVED HOSES, WATERLINES, SEATS, ETC., USING BEGINNING LIST AND WIRING DIAGRAM PROVIDED AS A GUIDELINE.

20. RUN CHECK OF ALL SYSTEMS, REWORK AS NECESSARY.

SCALE	DRAWN	T. JOHNSON
DATE	CHKD.	
12/5/91	APPD.	<i>SDW</i>
ENGINEERING DEPARTMENT		
TITLE		
FIELD FIX KIT, 190R II FUEL TANK		

DEC 17 1991

DESTROY PRIOR TO THIS DATE

BILL OF MATERIALS

(1) INSTRUCTION DWG., (5 SHEETS)	15-G549-00
(1 TUBE) RTV, SPORT BOAT GREY	44-0178-00
(11) OHMS, #10-24 X 1-1/2"	82-0198-01
(5) LOCKNUT, #10-24	82-1143-00
(5) FLATWASHER, #10	82-0164-00
(11 FT) PIPE INSULATION	43-0453-00
(25) OHSMS, #10 X 1-3/4"	82-3723-00
(1) BACK-UP PLATE	12-G550-00
(1.5 lbs) FOAM, PART A	44-0104-01
(1.5 lbs) FOAM, PART B	44-0104-02
(12) TYWRAP	12-8081-00

*These part numbers are no longer valid.
The back up plate should be aluminum stock(1/4").

SCALE	DRAWN	T. JOHNSON
DATE	CHKD.	
12/5/91	APPD.	SDW
ENGINEERING DEPARTMENT		
TITLE		
FIELD FIX KIT, 190R II FUEL TANK		

PRODUCTION
DEC 17 1991
DESTROY PRINT
BEFORE THIS DATE

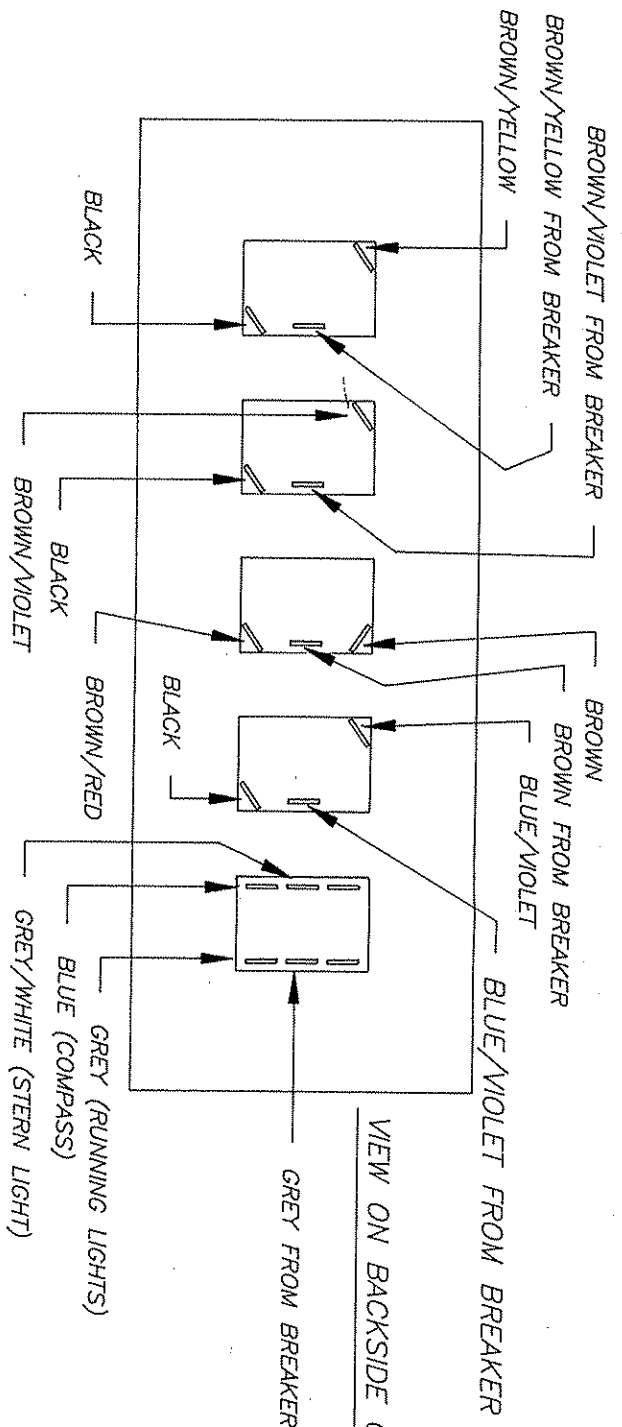

VIEW ON BACKSIDE OF HELM SWITCH PANEL

1. MARK ALL CENTER WIRES ON SWITCHES, THESE ARE THE CONDUCTORS FROM THE BREAKER PANEL. ONCE MARKED, REMOVE.
2. REMOVE BLACK GROUND WIRES FROM THE AERATOR, SALTWATER WASHDOWN, AND COURTESY LIGHT SWITCHES.
3. REMOVE BILGE PUMP WIRES
4. REMOVE THREE WIRES SHOWN FROM NAV LIGHT SWITCH.
5. REASSEMBLY IS THE REVERSE ORDER OF ABOVE.
6. DISCONNECT FUEL GAUGE AND COMPASS WIRING, (IF INSTALLED).
7. REMOVE BREAKER PANEL, THEN CUT TYWRAPS HOLDING HARNESS INSIDE CONSOLE.

DESTROY PRINTED
PARTS TO THIS DATE
DEC 17 1991

SCALE	DRAWN	T. JOHNSON
DATE	CHKD.	
12/5/91	APPD.	SDW
ENGINEERING DEPARTMENT		
TITLE		
FIELD FIX KIT, 190R II FUEL TANK		