

FMT-63A-BWE  
 P/N: 1021583  
 Wt: 88.2 Lbs  
 FINISH: GRAY PAINT

CUTTING SPECIFICATIONS:  
 BDY: 102 3/4 X 32 11/16  
 TOP: 102 3/4 X 21 1/8  
 END: 21 1/8 X 7 1/2  
 BAF: 22 5/8 X 9

REVISIONS:

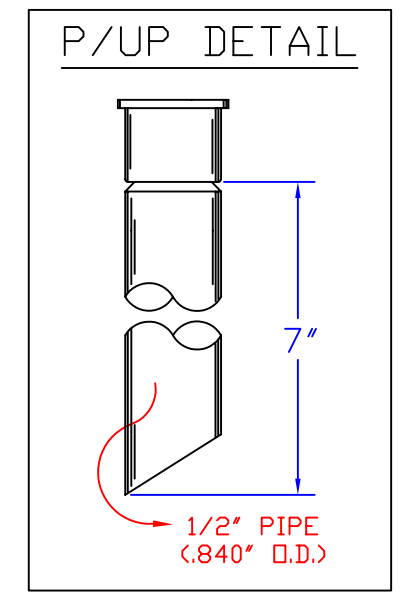
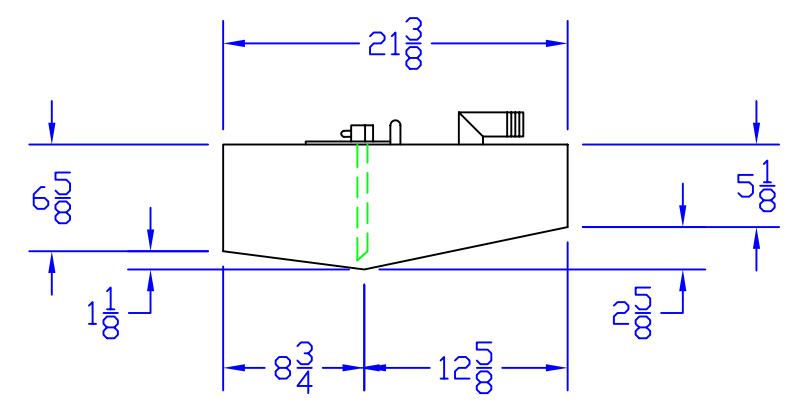

**FLORIDA MARINE TANKS, INC.**  
 16480 N.W. 48 AVE. HIALEAH, FL. 33014

BOSTON WHALER INC. 63A GALLON  
 FUEL TANK FOR 18' OUTRAGE.

DRAWN BY: J. BLANCO	SCALE: 1" = 1'	MATERIAL: .125" AL.
NET GAL:	DATE: 10-21-97	DRAWING NO: 12453500
CERT. DATE:	APP'D:	